

Simplex filter

EG3

Flanged connection, rated pressure up to 16 bar (232 psi)

Connecting sizes: DN 100 to DN 200, cast design

1. Features

High-performance filters for modern systems

- Entry-level model among Filtration Group GmbH products
- Used as a protective or safety filter in shipping and industry
- Simple, robust design
- Compact design
- Minimal pressure drop through optimal flow design
- Elements with high differential pressure stability and dirt holding capacity
- Filter ratings from 25 to 5000 μm absolute, other ratings on request
- Suitable for use with fluids of all types
- Easy to service
- Worldwide distribution



2. Operating principle

- The medium flows through the filter element (perforated, smooth or pleated) from the inside to the outside.
- Contaminants are trapped on the inside of the element.
- The filtration process is interrupted when a settable fouling threshold is reached.
- The filter is opened and the element removed for cleaning.
- Simplex filters require no maintenance apart from cleaning the filter elements and inspecting the seals.

3. Technical Data

Connection:	DN 100 to DN 200
Flange Type 1:	DIN 2501 PN 16
Material:	Nodular cast iron 40
Max. operating pressure Type 1:	6 bar
Max. operating pressure Type 2:	16 bar
Test overpressure Type1:	10 bar
Test overpressure Type2:	21 bar
Max. operating temperature:	180 °C
Filter element:	Screen basket, cartridge
Filter rating:	25 to 5000 µm absolute, other ratings on request

4. Dimensions

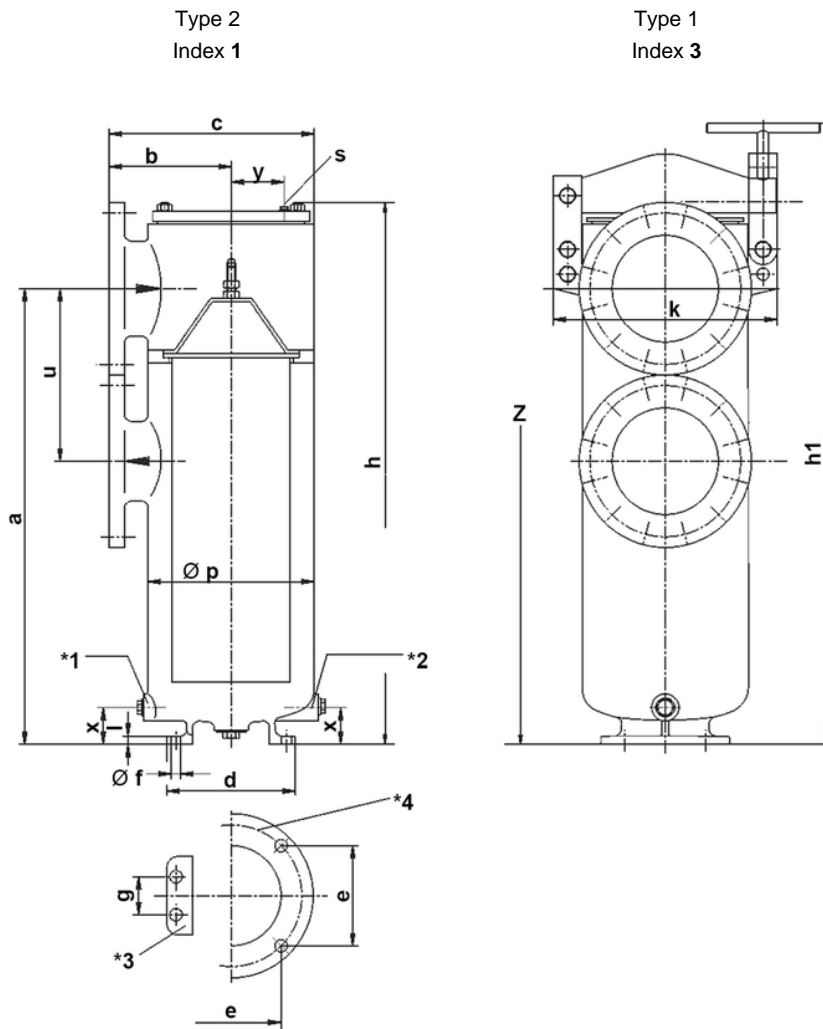

All dimensions except "s" in mm.

Type	DN	a	b	c	d	e	Ø f	g	h	h1	k	l	Ø p	s	u	x	y	Z	Weight [kg]
AE1031*0A09	100	480	173	282	220	180	18	70	594	676	234	16	204	G1/4	250	90	50	1018	57
AE1131*0A10	125	660	190	330	260	220	18	170	788	925	370	18	260	G3/8	270	130	80	1343	94
AE1231*0A11	150	760	230	375	320	270	23	200	909	1035	424	20	308	G3/8	310	135	100	1536	129
AE1431*0A13	200	810	270	445	290	176	23	-	996	1175	526	20	384	G3/8	350	90	120	1736	209

* Insert index "3" for type 1, insert index "1" for type 2

5. Design and application

A wide range of filter elements are available for every filter. The material, type of construction and filter surface and rating are expertly adapted to the specific filtration task based on the medium and capacity.

Each filter can be supplied with various options to ensure the optimum performance for each particular application.

Options:

- Heating with steam/thermal oil or electric
- Magnetic elements
- Differential pressure indicator/switch as a removable part
- Snap closing
- Internal coating or rubber coating

Simplex filters are not at all complicated to use. The necessary steps are described in the following:

- The filter comprises a cylindrical housing, a cover and a filter element. It is fitted with a vent screw and a drain plug.
- Stress relief must be provided for all pipe connections. The filter must be filled and vented before it is put into service. Install the filter piping so that the medium flows through the filter in the direction indicated by the arrow.
- During the filtration process, the medium flows through the filter element from the inside to the outside. Contaminants are trapped on the inside of the element. As the filter element becomes increasingly dirty, the flow resistance rises accordingly. The degree of fouling is indicated on the differential gauge (optional). The filter element must be cleaned when the pressure difference reaches 0.7 bar.
- In order to remove the filter element, loosen the cover fastening nuts on the depressurised filter and lift off the cover. The dirty element can then be withdrawn without any problems.
- To clean the filter element, either blow it out with compressed air, steam or water or brush it with a soft brush. Be careful not to damage the filter fabric or the perforated sheet and avoid pushing the element inwards as it is blown out. Pre-treat the element with a suitable solvent if the dirt deposits cannot be removed easily.

6. Type number key

Type number key with selection example for EG3 simplex filter with DN 100 to DN 250

Main product group

A Simplex filter, cast design

Series

E Simplex filter with filter element or cartridge

Inlet and outlet connections

10 Flange DN 100

11 Flange DN 125

12 Flange DN 150

14 Flange DN 200

15 Flange DN 250

Filter connection standard + rates pressure

3 EN 1092 PN 16 bar

Position of main connections

1 Stacked on the same side

Cover fastening

1 Stud bolts or hexagon screws

Options

0 Standard version

2 Electric cartridge heater

3 Steam/thermal cartridge heater

7 Version without non-ferrous metals

G Rubber coating

Type of inner assembly

A Filter elements for simplex filter

Inner assembly size

XX

Housing version

2 Nodular cast iron

Nozzle material

0 No material specified (not assigned)

Number for special types or design features

XX

00

A

E

12

3

1

1

0

A

11

2

0

00

Filtration Group GmbH
 Schleifbachweg 45
 D-74613 Öhringen
 Phone +49 7941 6466-0
 Fax +49 7941 6466-429
 sales@filtrationgroup.com
 www.filtrationgroup.com
 70381734.11/2016