

Simplex filter EG1

With threaded connection, rated pressure up to 16 bar (232 psi)
Connection sizes: G3/4" to G2", cast design

1. Features

High-performance filters for modern systems

- Entry-level model among Filtration Group GmbH products
- Used as a protective or safety filter in shipping and industry
- Simple, robust design
- Compact design
- Minimal pressure drop through optimal flow design
- Elements with high differential pressure stability and dirt holding capacity
- Filter ratings from 25 to 5000 μm absolute, other ratings on request
- Suitable for use with fluids of all types
- Easy to service
- Worldwide distribution



2. Operating principle

- The medium flows through the filter element (perforated, smooth or pleated) from the inside to the outside.
- Contaminants are trapped on the inside of the element.
- The filtration process is interrupted when a settable fouling threshold is reached.
- The filter is opened and the element removed for cleaning.
- Simplex filters require no maintenance apart from cleaning the filter elements and inspecting the seals.

3. Technical Data

Connection:	G $\frac{3}{4}$ " to G2"
Material:	Nodular cast iron 40
Max. operating pressure:	16 bar
Test overpressure:	24 bar
Max. operating temperature:	120 °C
Filter element:	Screen basket (perforated, smooth or pleated)
Filter rating:	25 to 5000 μ m absolute, other ratings on request

4. Dimensions

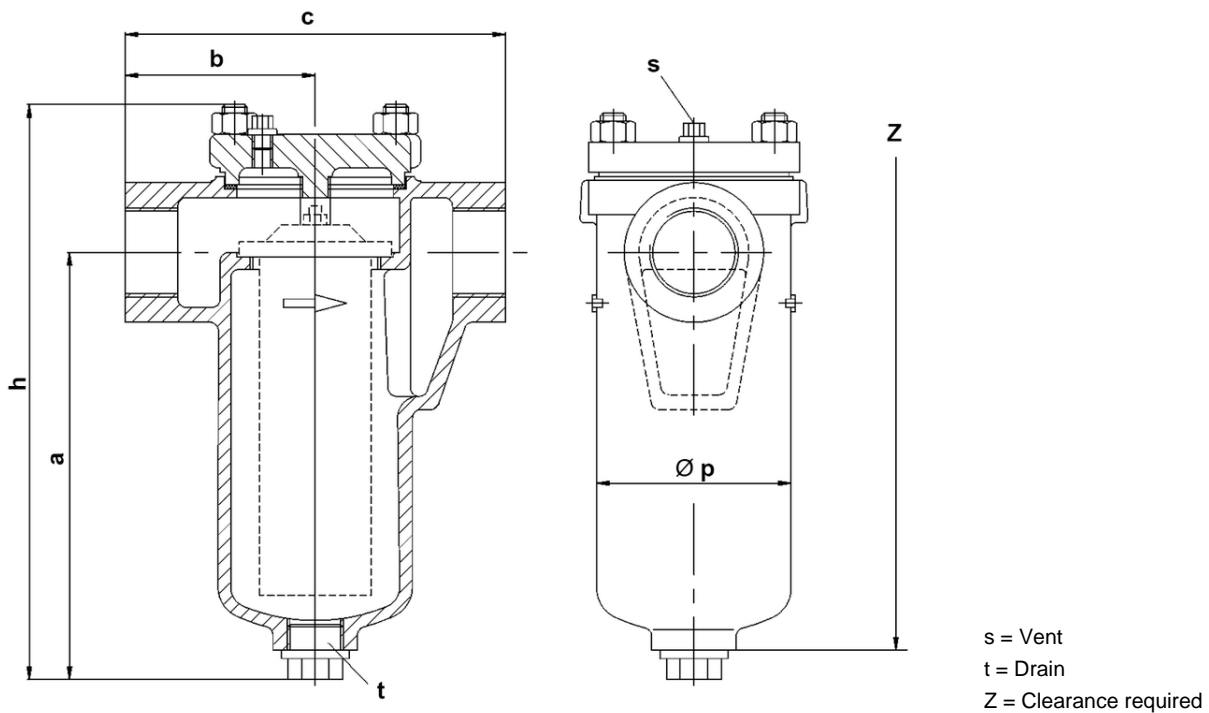

All dimensions except "DN", "s" and "t" in mm.

Type	DN	a	b	c	h	Ø p	s	t	Z	Weight [kg]
AE45T210A02	G3/4	131	65	130	185	70	-	G3/8	275	3.0
AE46T210A03	G1	150	75	150	215	90	G1/8	G3/4	315	5.0
AE47T210A04	G1 1/4	201	90	180	265	90	G1/8	G3/4	420	6.0
AE48T210A05	G1 1/2	263	100	235	340	126	G1/4	G1	535	11.0
AE49T210A05	G2	263	100	235	340	126	G1/4	G1	535	11.0

5. Design and application

A wide range of filter elements are available for every filter. The material, type of construction and filter surface and rating are expertly adapted to the specific filtration task based on the medium and capacity.

Each filter can be supplied with various options to ensure the optimum performance for each particular application.

Options:

- Heating with steam/thermal oil or electric
- Magnetic elements
- Differential pressure indicator/switch as a removable part

Simplex filters are not at all complicated to use. The necessary steps are described in the following:

- The filter comprises a cylindrical housing, a cover and a filter element. It is fitted with a vent screw and a drain plug.
- Stress relief must be provided for all pipe connections. The filter must be filled and vented before it is put into service. Install the filter piping so that the medium flows through the filter in the direction indicated by the arrow.
- During the filtration process, the medium flows through the filter element from the inside to the outside. Contaminants are trapped on the inside of the element. As the filter element becomes increasingly dirty, the flow resistance rises accordingly. The degree of fouling is indicated on the differential gauge (optional). The filter element must be cleaned when the pressure difference reaches 0.7 bar.
- In order to remove the filter element, loosen the cover fastening nuts on the depressurised filter and lift off the cover. The dirty element can then be withdrawn without any problems.
- To clean the filter element, either blow it out with compressed air, steam or water or brush it with a soft brush. Be careful not to damage the filter fabric or the perforated sheet and avoid pushing the element inwards as it is blown out. Pre-treat the element with a suitable solvent if the dirt deposits cannot be removed easily.

6. Type number key

Type number key with selection example for EG1 simplex filter with G½" to G2" threaded connection

Main product group

A Simplex filter, cast design

Series

E Simplex filter with filter element

Inlet and outlet connections

- 45 G¾" threaded connection
- 46 G1" threaded connection
- 47 G1¼" threaded connection
- 48 G1½" threaded connection
- 49 G2" threaded connection

Filter connection standard + rated pressure

T PN 16 bar

Position of main connections

2 Opposite each other on the same axis

Cover fastening

1 Stud bolts or hexagon screws

Options

- 0 Standard version
- 2 Electric cartridge heater
- 3 Steam/thermal cartridge heater
- 7 Version without non-ferrous metals

Type of inner assembly

A Filter elements for simplex filter

Inner assembly size

XX

Housing version

2 Nodular cast iron

Nozzle material

0 No material specified (not assigned)

Number for special types or design features

XX

A E 45 T 2 1 0 A 02 2 0 00

Filtration Group GmbH
 Schleifbachweg 45
 D-74613 Öhringen
 Phone +49 7941 6466-0
 Fax +49 7941 6466-429
 sales@filtrationgroup.com
 www.filtrationgroup.com
 70381728.11/2016