

Automatic filter AF 153 G

with scraper and external pressure cleaning
Connection sizes: DN 50/G2, cast stainless steel

1. Features

Filtration Group automatic backflush filters are suitable for all applications where low or medium-viscosity liquids have to be filtered.

These compact, inline filter systems are designed for automatic cleaning. The system is cleaned by rotating the filter cartridge against a spring actuated scraper and backflushing with external pressure media.

Advantages:

- Low lifecycle costs because no filter material is consumed
- Cleaning without interrupting filtration
- Precise separation quality in accordance with the surface filter principle
- Top-quality, asymmetric filter medium made of multiple-sintered stainless steel fleece on a rugged inner core
- Efficient filter cleaning assures maximum process stability
- Solid construction and high-quality materials for a long service life
- Minimal liquid loss during cleaning
- Filter cleaned one segment at a time with a high backflush pulse
- Actual filter rating and nominal separation are indicated
- Integrated preseparation thanks to tangential inflow and preseparator tube
- Material variants open up a wide range of applications
- Modular Filtration Group Vario system for optimum filter selection
- Optional: Gas-tight shaft seals available
- Optional: Application in Ex zone 1 and 2
- Optional: Certification for Pressure Equipment Directive (PED) according to category III PED EN
- Easy maintenance
- Worldwide distribution



2. Operating principle

The combined Filtration Group AF 153 G backflush filter belongs to the Vario series. The compact Filtration Group automatic filter system is used for filtration of a variety of low or medium-viscosity liquids.

This inline pressure filter consumes no filter material, which means there is also no need for subsequent disposal. The filter can be cleaned after switching off the system or, if necessary, without interrupting operation. The concentrated solids are drained off simply by opening the system for a short time.

The medium to be cleaned is guided into the filter housing under pressure. It flows inward through the Filtration Group segmented element. Particles settle on the surface of the filter medium. The filtered fluid exits the filter housing at the top opposite the inlet connection.

The filter is cleaned when a preset differential pressure limit, a set interval or a defined filtered fluid quantity is reached.

The segmented element is turned against a spring actuated scraper as the drain and external pressure valves are opened. The segments are then guided one at a time past the pressure channel housing on the inside and the scraper on the outside. This causes them to open and close alternately. The integrated external pressure accumulator is pretensioned during closing, so that when one segment opens, an outward surge cleans the separated particles from the filter material. The particles are catapulted out as a result of this pulse cleaning principle. One turn suffices to clean all segments.

The residue that has settled in the collection cone can be emptied via the drain valve either when the machine is at a standstill or during filtration.

All filters in the Filtration Group Vario series are protected by patents.

Used Filtration Group filter cartridges in the AF 153 G combined backflush filter:

Filtration Group coiled cartridge:

- Optimum cleaning by means of sharp-edged triangular wire
- Large effective filter surface
- Small, precise gap widths
- High differential pressure stability and torsional strength
- Several material combinations possible

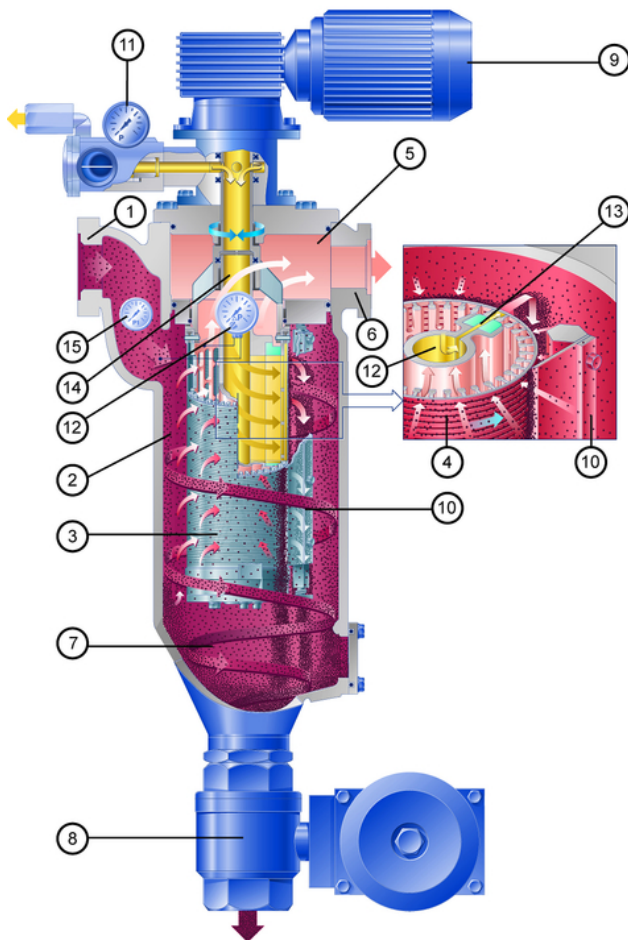
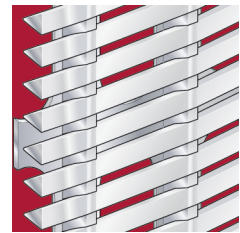

- 1 Tangential inlet connection
- 2 Inlet plenum
- 3 Filtration Group coiled cartridge
- 4 Filtration Group triangular wire winding
- 5 Plenum for filtered fluid
- 6 Outlet connection for filtered fluid
- 7 Residue collection cone
- 8 Drain valve
- 9 Drive motor
- 10 Scraper
- 11 External pressure connection, external pressure and back-flush valves and gauge
- 12 Differential pressure contact gauge
- 13 External pressure nozzle
- 14 External pressure accumulator
- 15 P1 gauge

3. Technical data

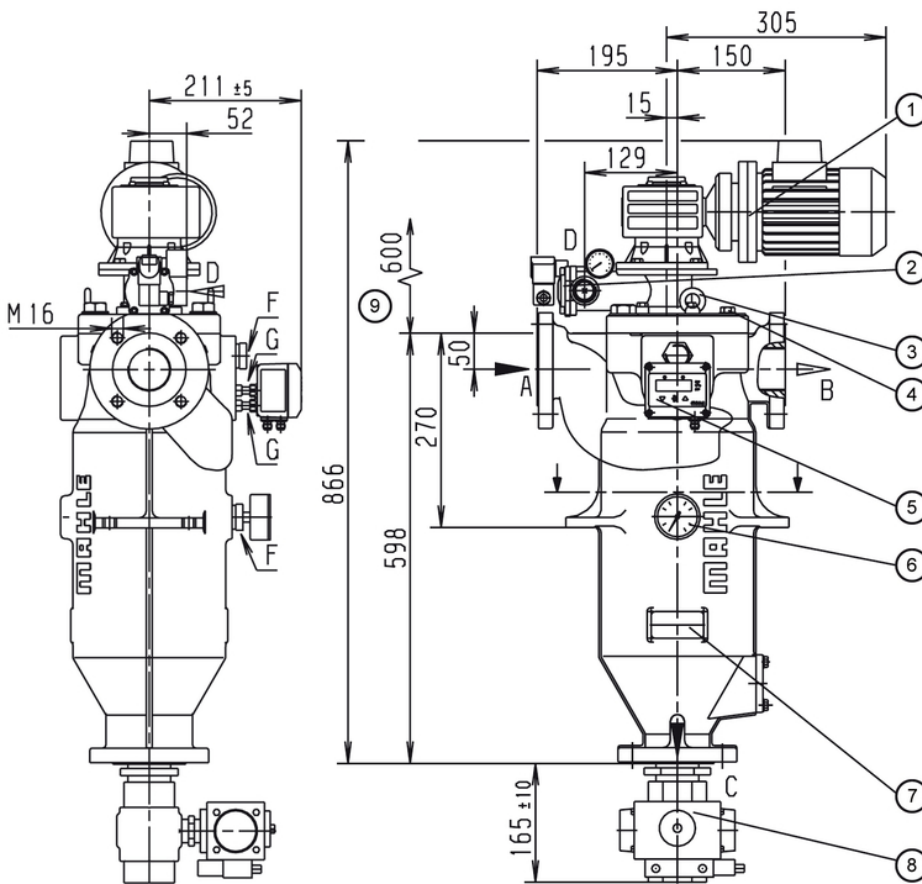

- 1 Cleaning drive: can be mounted turned 90°, 180° or 270°
- 2 External pressure valve
- 3 Lifting eyebolts
- 4 Vent screw G1/4
- 5 Optional: Differential pressure indicator/switch/gauge
- 6 Optional: P1 gauge
- 7 Name-plate
- 8 Optional: Automatic drain valve
- 9 Clearance required = 600 mm

Filter data

Max. operating pressure: 16 bar

Max. operating temperature: 100 °C

Materials:

- Housing and cover: Cast steel 1.4581, 1.4408
- Optional: Certificate acc. to EN 10204-3.1
- Internals: Cast steel 1.4581, stainless steel 1.4571
- Bearing bushes: PTFE based
- Seals: FPM (Viton)
- Coiled cartridge: 1.4571 or 1.4571/Al/hc (Δp max. 30 bar)

Cover fastening:

- 4 x M20 hexagon screws

Connections and nominal diameters:

- A-inlet, B-outlet, C-drain: G2 threaded hole in flange DN 50
- D-external pressure: G1 (air: must be reduced to G1/2 by the customer)
- F-gauge: G1
- G-indicator: G1/8
- All threaded holes acc. to DIN 3852 form Z

Drive shaft seal:

Lip seal with O-ring

Motor data

Worm gear motor

Multi-range winding

V	Hz	kW	U/min	A
Δ 230 \pm 10%	50	0.18	9.3	1.2
λ 400 \pm 10%	50	0.18	9.3	0.7
Δ 266 \pm 10%	60	0.22	11.2	1.1
λ 460 \pm 10%	60	0.22	11.2	0.7

Protection class: IP55; insulation class F; output torque: 97 Nm

Optional:

- Ex protection acc. to ATEX 2014/34/EU
- Electrical components in Ex II 2G T3
- Mechanical design in Ex II 2G c T3
- Worm gear motor Ex, output torque: 97 Nm

Weight: 92 kg

Volume: 12 l

Other types available on request!

Technical data is subject to change without notice

4. Design and application

Cartridge type (see section 6)	Total surface in cm ²	Filter rating in μm / effective filter surface in cm ²											
		10	20	30	40	60	80	100	130	160	200		
AF 130XX6	818			48	63	91	117	142	176	206			

 Recommended design

Cleaning and emptying

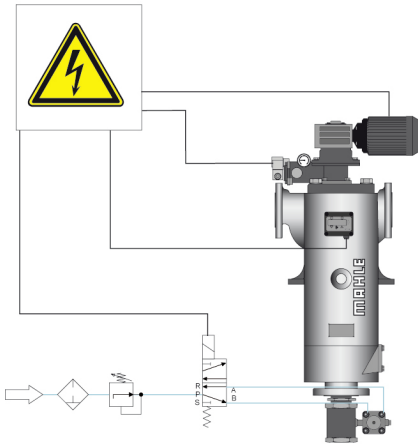

Fully automatic operation:

Filtration usually takes place under pressure. The filter is cleaned after a programmed time or a preset number of cycles or according to the differential pressure. We recommend cleaning the system at a differential pressure of approximately 0.5 to 0.7 bar. The cleaning motor is operated for around 7 s (about one turn of the filter cartridge). The external pressure and drain valves can be opened for this period. This suffices to clean the filter thoroughly.

The drain valve is opened in order to empty the filter. Depending on the residue concentration, this can either take place directly after cleaning or be time or cycle controlled. The opening time of the drain valve is 2 to 3 s.

Refer to the Instruction Manual for further information.



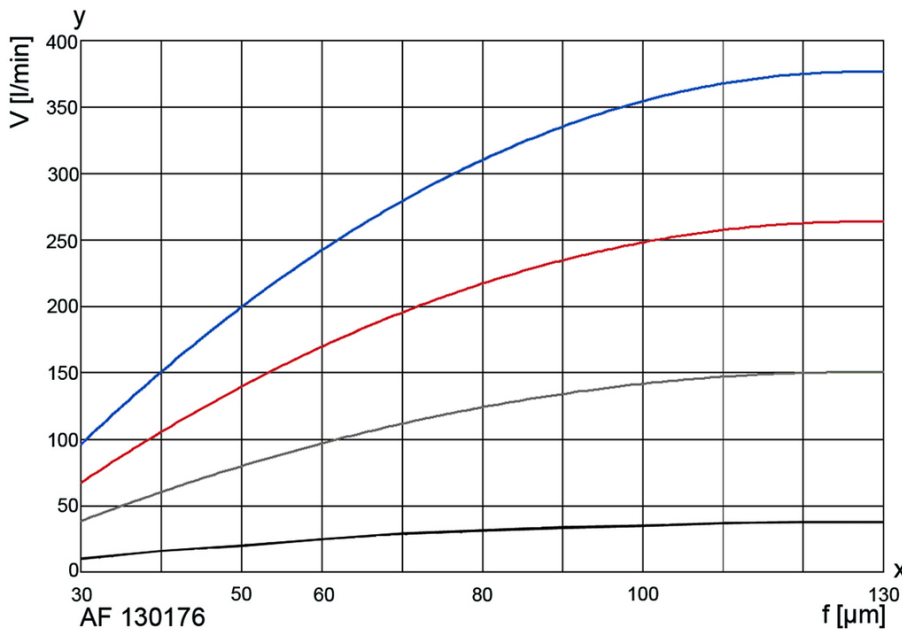

Filtration Group's team of specialists will be pleased to assist in any way. Tests can be carried out in the absence of reliable evaluation criteria.

5. Efficiency curves



The curves indicate the volume flow through the complete filter system (filter housing including cartridge) and are referred to a differential pressure of 0.3 bar. Specific process information is essential to guarantee reliable operation of an automatic filter.

Viscosity in mm²/s

-  1 mm²/s
-  33 mm²/s
-  100 mm²/s
-  500 mm²/s

y = Volume flow V [l/min]
x = Gap width f [μm]

6. Type number key

Type number key with selection example for AF 15363-1322-43200/G3										
Size										
AF 1536	1	x 110x265	No. of steps x diameter x length [mm]							
Cleaning drive										
	3	Gear motor 230/400 V, 50 Hz or 266/460 V, 60 Hz								
	4	Gear motor 230/400 V, 50 Hz Ex II 2G T3								
Inlet and outlet connections										
	3	DN 50								
	13	G2								
Permissible operating pressure in bar (housing/cover)										
	2	PN 16								
Material Seal FPM, bearing PTFE										
	2	Housing and cover stainless steel 1.4581/1.4571								
Differential pressure indicator and gauge										
	1	PiS 3076, switching level at 1.2 bar, static 63 bar								
	2	PiS 3076, switching level at 0.7 bar, static 63 bar								
	4	PiS 3170, digital Δp gauge, 2 switching levels settable from 0 to 16 bar								
	5	PiS 3175, digital Δp gauge, 2 pressure transmitters settable from 0 to 16 bar								
Valves and control throttles										
	3	External pressure valve G1 for liquid, 24 V								
	4	External pressure valve G1 for liquid, 230 V								
Drain valve										
	2	Ball valve, electropneumatic 24 V								
	3	Ball valve, electropneumatic 230 V								
	4	Ball valve, electric 24 V								
	5	Ball valve, electric 230 V								
Cleaning valve										
	0	Without/special version								
Optional features										
	0	Without/special version								
AF 1536	3	- 13	2	2	-4	3	2	0	0	-XXXX (end number for special version)/G3*

**end number completion:

G1 cast iron, Version 1

G3 cast iron, Version 3

End number	Special version
3001	Standard complete inner assembly, without housing or drive
3002	Standard complete inner assembly, without housing, with drive
3700	PTFE seals
Other numbers	On request

Type number key with selection example for coiled or welded cartridges for AF 130

Series

AF 130 Segmented element with triangular wire winding

Material	Core element	Filter medium	Clamp rings	Wire width in mm
----------	--------------	---------------	-------------	------------------

Coiled cartridge

20	Al/hc	1.4571	1.4571	0.5
----	-------	--------	--------	-----

Overall length Diameter x length in mm

6	110 x 265
---	-----------

Gap width/rating in µm (see 4. Design and application)

003	30 µm	010	100 µm
004	40 µm	013	130 µm
006	60 µm	016	160 µm
008	80 µm	020	200 µm

Other filter ratings on request

AF 130 20 6 -010

7. Spare parts

No.	Designation	Material no.	
		FPM/C steel	PTFE/VA
1	Bush kit		70311579
2	Seal kit (complete)	70316111	70316118
3	Scraper	70310724	70310731
4	Distributor		70511099
5	Filter cartridge		See name-plate

Please contact us for detailed technical information, any open questions about options, accessories and for general expert advice. Completion of the relevant questionnaire would facilitate in the coordination of all important parameters.

Comprehensive documentation on our filter range, filter elements and accessories can be provided. About installation and operation, please refer to the Instruction Manual

Filtration Group GmbH
 Schleifbachweg 45
 D-74613 Öhringen
 Phone +49 7941 6466-0
 Fax +49 7941 6466-429
 sales@filtrationgroup.com
 www.filtrationgroup.com
 70360057.11/2016