

## Duplex Filter Pi 281

Nominal pressure 10/16 bar (140/230 psi), nominal size 1250 up to 8000

### 1. Features

#### High performance filters for modern hydraulic systems

- Modular system
- Compact design
- Minimal pressure drop through optimal flow design
- Visual/electrical/electronic maintenance indicator
- Flanged connections
- Quality filters, easy to service
- Equipped with highly efficient glass fibre PS filter elements
- Beta rated elements according to ISO 16889 multipass test
- Elements with high differential pressure stability and dirt holding capacity
- Worldwide distribution

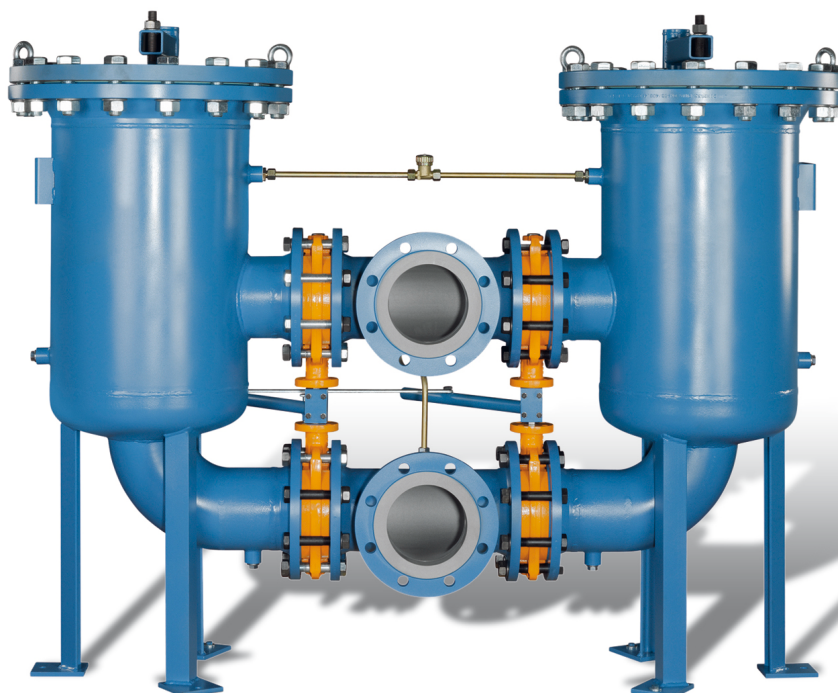

## 2. Flow rate/pressure drop curve complete filter

190 mm<sup>2</sup>/s  
33 mm<sup>2</sup>/s

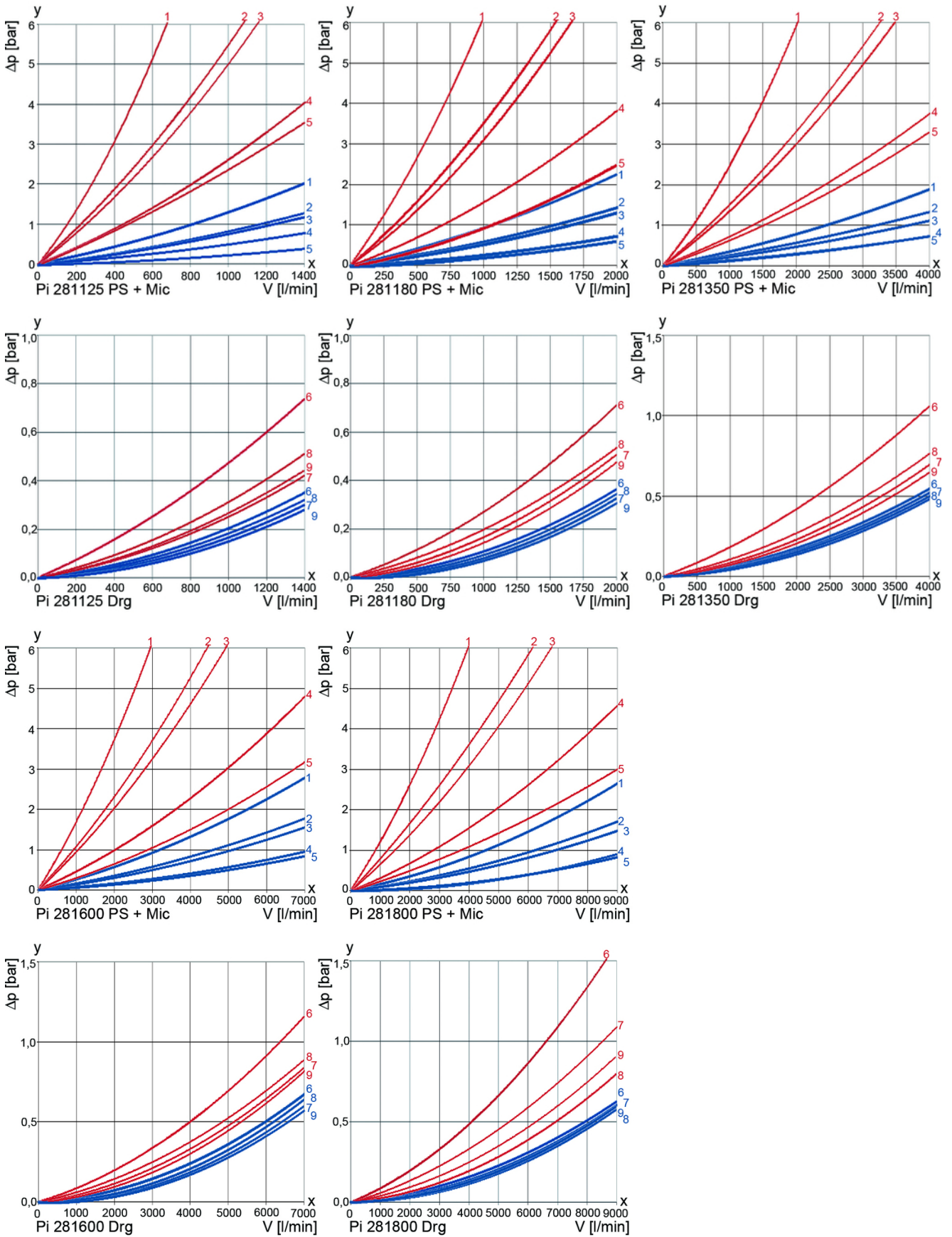

y = differential pressure  $\Delta p$  [bar]

x = flow rate V [l/min]

1 = PS 3  
2 = PS 6

3 = PS 10  
4 = PS 25

5 = Mic 10  
6 = Drg 25

7 = Drg 40  
8 = Drg 60

9 = Drg 100

### 3. Separation grade characteristics

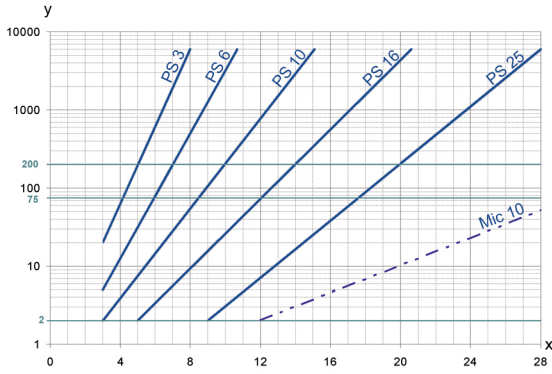

y = beta-value  
x = particle size [ $\mu\text{m}$ ]

determined by multipass tests (ISO 16889)  
calibration according to ISO 11171 (NIST)

### 4. Filter performance data

tested according to ISO 16889 (multipass test)

PS elements with  
max.  $\Delta p$  10 bar

PS	3	$\beta_{5(C)} \geq 200$
PS	6	$\beta_{7(C)} \geq 200$
PS	10	$\beta_{10(C)} \geq 200$
PS	25	$\beta_{20(C)} \geq 200$

values guaranteed at  
5 bar differential pressure

### 5. Quality assurance

Filtration Group filters and filter elements are produced according to the following international standards:

Norm	Designation
DIN ISO 2941	Hydraulic fluid power; filter elements, verification of collapse/burst resistance
DIN ISO 2942	Hydraulic fluid power; filter elements, verification of fabrication integrity
DIN ISO 2943	Hydraulic fluid power; filter elements, verification of material compatibility with fluids
DIN ISO 3723	Hydraulic fluid power; filter elements, method for end load test
DIN ISO 3724	Hydraulic fluid power; filter elements, verification of flow fatigue characteristics
ISO 3968	Hydraulic fluid power-filters-evaluation of pressure drop versus flow characteristics
ISO 10771.1	Fatigue pressure testing of metal containing envelopes in hydraulic fluid applications
ISO 16889	Hydraulic fluid power filters-multi-passmethod for evaluation filtration performance of a filter element

### 6. Symbols

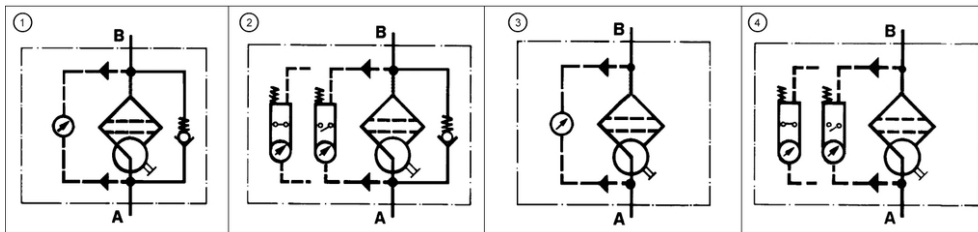

## 7. Type code and order numbers

### Pi 281125/21-058/852 888 PS 10

<b>Pi 281</b>	<b>125</b>	<b>/2</b>	<b>1</b>	<b>-058</b>	<b>/825 888 PS 10</b>
1	2	3	4	5	6

1 Filter type

2 Size/Connections 125 = 1250 l/min - DN 100

Connection flange 180 = 1800 l/min - DN 125

(In, Out): DIN EN 1092-1 350 = 3500 l/min - DN 150

600 = 6000 l/min - DN 200

800 = 8000 l/min - DN 250

3 Nominal pressure 1 = 10 bar

2 = 16 bar

4 Number of elements 1 per filter side from NG 1250 up to NG 1800,

3 per filter side from NG 3500 up to NG 6000,

4 per filter side at NG 8000

5 Housing design 058 = with bypass valve and electrical maintenance indicator

069 = electrical maintenance indicator

6 Filter element Filter element type and filter rating

Filters DN 100 and DN 125 optional, DN 150 up to DN 250 standard with cover lifting device.

#### 7.1 Housing design

Nominal size NG [l/min]	Type	Number of elements per filter side and element type	Pressure [bar]	② with bypass valve and electrical indicator	④ with electrical indicator
1250	281125/11-058	1x 852 888	10		
	281125/11-069				
	281125/21-058		16		
	281125/21-069				
1800	281180/11-058	1x 852 884	10		
	281180/11-069				
	281180/21-058		16		
	281180/21-069				
3500	281350/13-058	3x 852 888	10		
	281350/13-069				
	281350/23-058		16		
	281350/23-069				
6000	281600/13-058	3x 852 884	10		
	281600/13-069				
	281600/23-058		16		
	281600/23-069				
8000	281800/14-058	4x 852 884	10		
	281800/14-069				
	281800/24-058		16		
	281800/24-069				

## 7.2 Filter elements (a wider range of element types is available on request)

Order number	Type	Filter material	max. $\Delta p$ [bar]	Filter surface [cm <sup>2</sup> ]
78263295	852 888 PS 3	PS 3	10	21850
78354029	852 888 PS 6	PS 6		21850
78226813	852 888 PS 10	PS 10		21850
78226821	852 888 PS 25	PS 25		21850
78207664	852 888 Mic 10	Mic 10		21850
78228017	852 888 Drg 25	Drg 25		16500
78228025	852 888 Drg 40	Drg 40		16500
78303026	852 888 Drg 60	Drg 60		16500
78228470	852 888 Drg 100	Drg 100		16500
78227431	852 884 PS 3	PS 3		10
79337916	852 884 PS 6	PS 6	28500	
78226797	852 884 PS 10	PS 10	28500	
78226805	852 884 PS 25	PS 25	28500	
70366315	852 884 Mic 10	Mic 10	28500	
79337460	852 884 Drg 25	Drg 25	23450	
78261653	852 884 Drg 40	Drg 40	23450	
79700402	852 884 Drg 60	Drg 60	23450	
79327750	852 884 Drg 100	Drg 100	23450	

## 8. Technical specifications

Design:	line mounting filter, mounting via through holes at supporting stands
Fitting position:	upright
Butterfly valve switch over device	
Temperature range:	- 10 °C to + 100 °C (other temperature ranges on request)
Filter housing material:	steel welded construction
Material of seals:	NBR (other materials on request)
Bypass opening pressure:	$\Delta p$ 3.5 bar +/- 10 %
Activating pressure of optical/electrical contamination indicator:	$\Delta p$ 2.2 bar +/-10 %
Electrical data of contamination indicator:	
Maximum voltage:	230 V AC/200 V DC
Maximum current on contact:	1 A
Maximum contact load:	70 W
Type of protection:	IP 65 when inserted and secured
Contact:	bistable
Cable connection:	M20x1.5
Please contact us in case of using other media.	

The switching function can be changed by turning the electric upper part by 180° (normally closed contact or normally open contact). The state on delivery is a normally closed contact. By inductivity in the direct current circuit the use of suitable protection circuit should be considered. Further maintenance indicator details and designs are available in the maintenance indicator data sheet.

We recommend you to contact us concerning applications of our filters in areas governed by the EU Directive 94/9 EC (ATEX 95). The standard version can be used for liquids based on mineral oil (corresponding to the fluids in Group 2 of Directive 97/23 EC Article 9). If you consider to use other fluids please contact us for additional support.

Subject to technical alteration without prior notice.

## 9. Dimensions

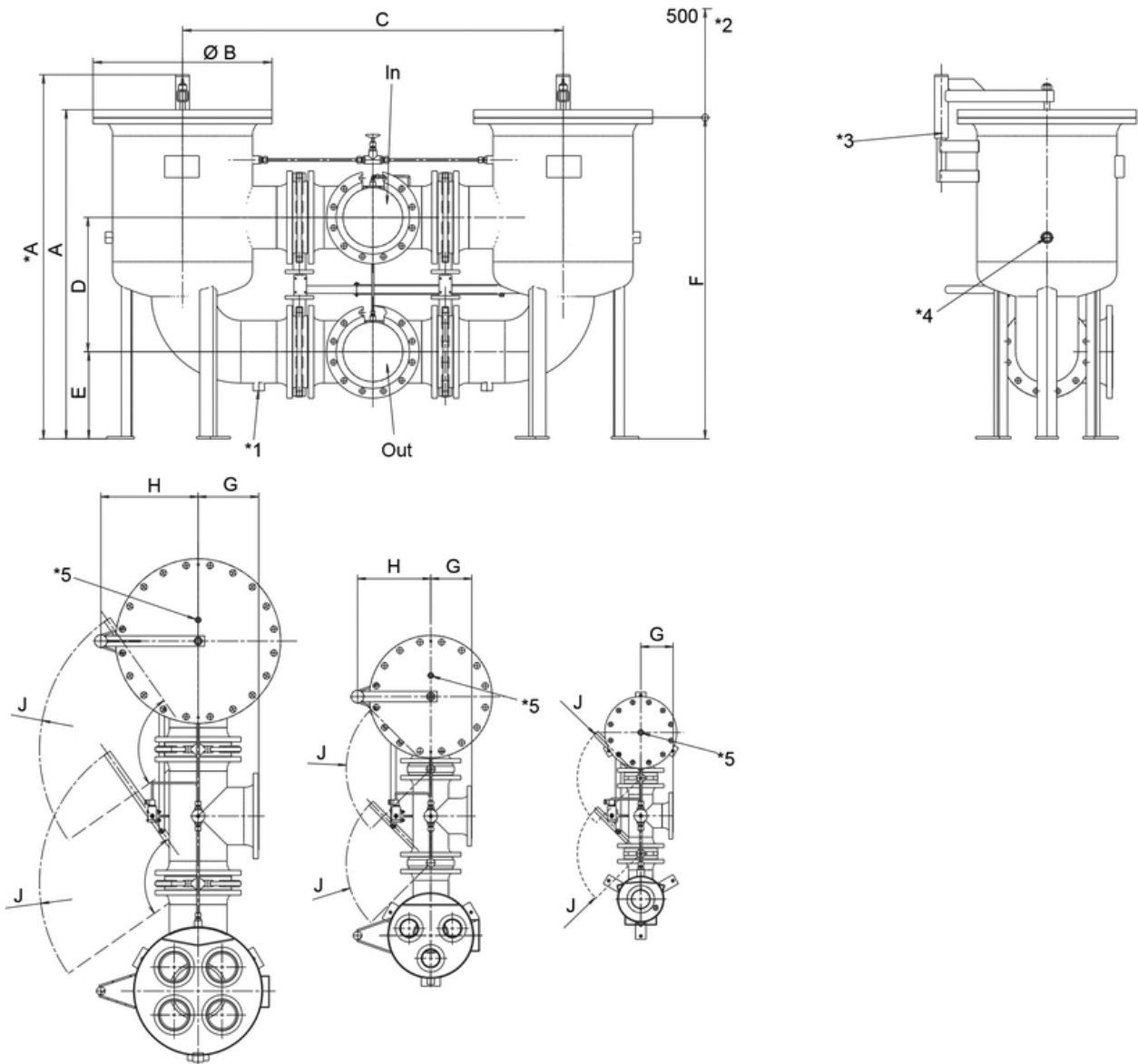

A for Pi 281125 up to 281180  
 \*A for Pi 281350 up to 281800

\*1 drain connection G $\frac{1}{2}$   
 \*2 minimum clearance

\*3 cover lifting device  
 \*4 drain connection G $\frac{1}{2}$

\*5 vent screw G $\frac{1}{2}$  In = Inlet  
 Out = Outlet

All dimensions in mm.

Nominal size NG [l/min]	Connection DN	Nominal pressure PN [bar]	A $\pm 10$	B	C $\pm 10$	D $\pm 1$	E $\pm 1$	F	G	H	J
1250	100	10 + 16	984	340	790	365	250	960	153	-	378
1800	125		1091	405	922	391	250	975	175	250	378
3500	150	16	1346	580	1132	435	332	1200	194	340	396
6000	200		1466	715	1332	483	350	1300	236	400	421
8000	250		1610	840	1654	587	380	1403	279	490	726
3500	150	10	1346	565	1132	435	332	1200	194	340	396
6000	200		1450	670	1332	483	350	1300	236	380	421
8000	250		1590	780	1654	587	380	1403	279	460	726

Filtration Group GmbH, Schleifbachweg 45, D-74613 Öhringen, Phone +49 7941 6466-0,  
 Fax +49 7941 6466-429, sales@filtrationgroup.com, www.filtrationgroup.com, 70366830.04/2015