

Suction return line filter Pi 550

Nominal pressure 10 bar, nominal size 100

1. Features

High-performance filters for modern stationary and mobile hydraulic systems

- Provided for tank top installation
- Very low overall height since suction and return line connections are very close together
- Minimum pressure drop through optimum flow design
- Electrical maintenance indicator
- Version with threaded connectors
- Service-friendly
- Equipped with highly efficient PS filter elements, with optional feeding filter stage
- Optional elements with filtration of the feeding volume flow available
- Beta rated elements according to ISO 16889 multipass test
- High dirt holding capacity thanks to large filter surface
- Worldwide distribution



2. Flow rate/pressure drop curves complete filter

190 mm²/s
33 mm²/s

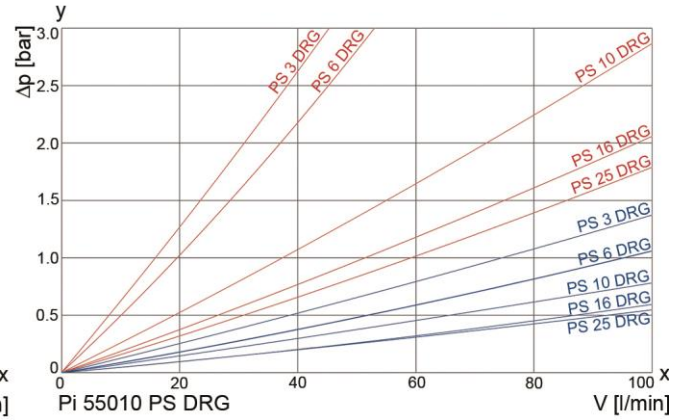
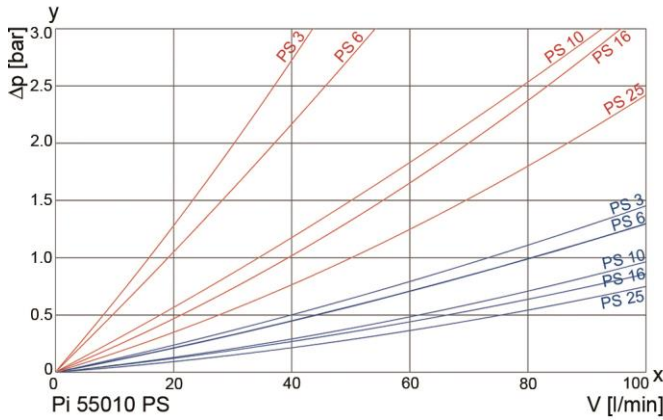

y = differential pressure Δp [bar]
x = flow rate V [l/min]

3. Separation grade characteristics

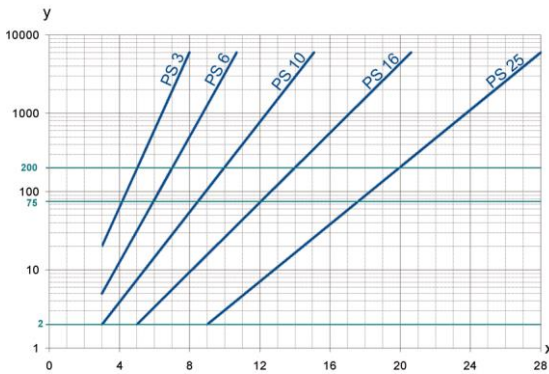

y = beta value
x = particle size [μm]

determined by multipass tests (ISO 16889)
calibration in accordance with ISO 11171 (NIST)

4. Filter performance data

tested in accordance with ISO 16889 (multipass test)

PS elements with
max. Δp 20 bar

PS 3 $\beta_{5(C)} \geq 200$
PS 6 $\beta_{7(C)} \geq 200$
PS 10 $\beta_{10(C)} \geq 200$
PS 16 $\beta_{15(C)} \geq 200$
PS 25 $\beta_{20(C)} \geq 200$

up to 10 bar differential pressure up to 20 bar differential pressure

5. Quality assurance

FGC filters and filter elements are manufactured and/or tested in compliance with the following international standards:

Norm	Designation
DIN ISO 2941	Hydraulic fluid power filter elements; verification of collapse/burst resistance
DIN ISO 2942	Hydraulic fluid power filter elements; verification of fabrication integrity
DIN ISO 2943	Hydraulic fluid power filter elements; verification of material compatibility with fluids
DIN ISO 3723	Hydraulic fluid power filter elements; method for end load test
DIN ISO 3724	Hydraulic fluid power filter elements; verification of flow fatigue characteristics
ISO 3968	Hydraulic fluid power-filters-evaluation of pressure drop versus flow characteristics
ISO 10771.1	Fatigue pressure testing of metal containing envelopes in hydraulic fluid applications
ISO 16889	Hydraulic fluid power filters-multipass method for evaluating filtration performance of a filter element

6. Symbols

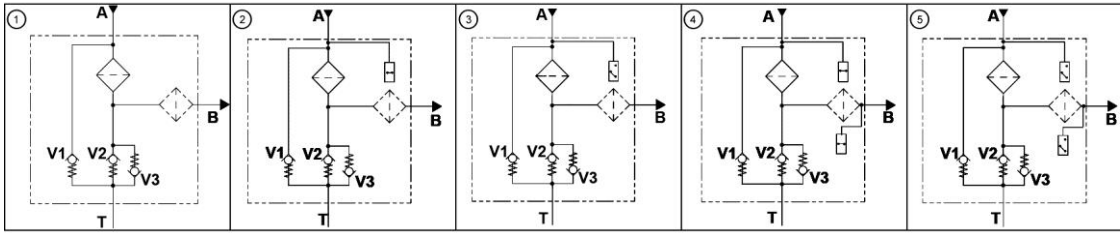

V1 = bypass valve
V2 = preloaded valve
V3 = feeding valve

7. Order numbers

Example for ordering filters:

1. Filter housing	2. Filter element
V=100 l/min Type: Pi 55010/01/-200 Order number: 72338649	PS 10 DRG Type: Pi 852 101 PS 10 DRG Order number: 70530136

7.1 Housing design							
Nominal size NG [l/min]	Order number	Type	① without DS	② DSO	③ DSS	④ DSO/USO	⑤ DSS/USS
100	72338649	Pi 55010/01/-200					
	72338651	Pi 55010/01/-201					
	72338652	Pi 55010/01/-202					
	72338654	Pi 55010/01/-203					
	72338655	Pi 55010/01/-204					

All versions with bypass valve 3.5 bar, preloaded valve 0.5 bar and feeding valve

DSO Pressure switch normally closed Δp 2,2 bar

USO Ported vacuum switch normally closed Δp 0,2 bar

DSS Pressure switch normally open Δp 2,2 bar

USS Ported vacuum switch normally open Δp 0,2 bar

7.2 Filter elements (other element versions on request)					
Nominal size NG [l/min]	Order number	Type designation	Filter material	max. Δp [bar]	Filter surface [cm ²]
100	72397561	852 101 PS 3	PS 3	10	1800
	72397562	852 101 PS 6	PS 6		
	70530086	852 101 PS 10	PS 10		
	70530087	852 101 PS 16	PS 16		
	72397563	852 101 PS 25	PS 25		
	72397565	852 101 PS 3 DRG	PS 3 DRG		1800
	72397566	852 101 PS 6 DRG	PS 6 DRG		
	70530136	852 101 PS 10 DRG	PS 10 DRG		
	70530137	852 101 PS 16 DRG	PS 16 DRG		
72397567	852 101 PS 25 DRG	PS 25 DRG			

8. Technical data

Design:	Suction return line filter
Nominal pressure Pi 55010	10 bar
Test pressure Pi 55010	15 bar
Temperature range:	-30 °C to +100 °C
	Survival temperature -40 °C (other temperature ranges on request)
Charging pressure:	Δp 0.5 bar
Switching pressure vacuum switch:	200 mbar
Switching pressure dynamic pressure switch:	2.2 bar
Bypass opening pressure:	Δp 3.5 bar
Filter head material:	AL
Filter housing material:	PA
Sealing material:	NBR

The maintenance indicator data sheet contains further details and other maintenance indicator versions.

We draw attention to the fact that all values indicated are average values. Our products are continually being further developed. Values, dimensions and weights can change as a result of this. Our specialist department would be pleased to offer you advice.

We recommend you contact us concerning applications for our filters in areas governed by the EU Directive 94/9 EC (ATEX 95). The standard version can be used for liquids based on mineral oil (corresponding to the fluids in Group 2 of Directive 97/23 EC Article 9). Please contact us if you intend using other media.

Subject to technical alteration without notice.

9. Dimensions

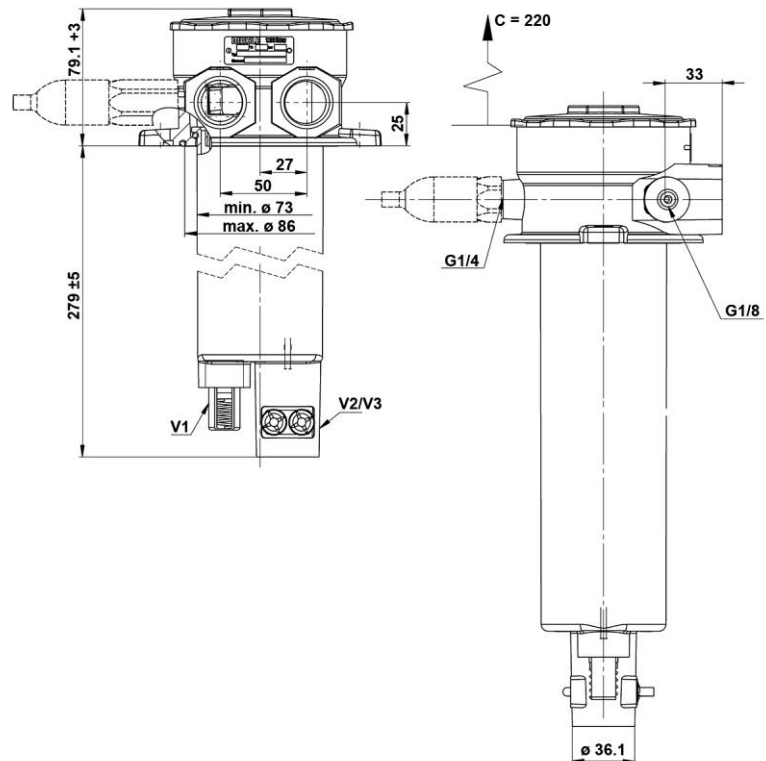
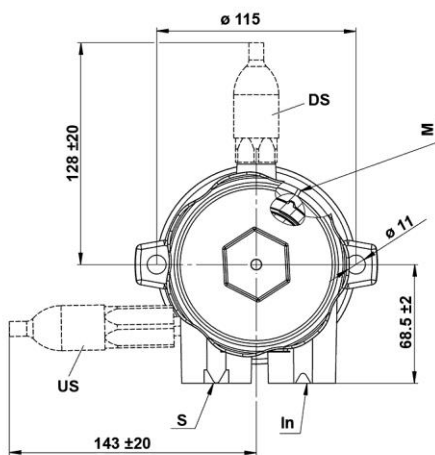

- C = dismantling height required 220 mm
- DS = pressure switch
- US = vacuum switch
- In = inlet
- M = marking for housing installation
- S = suction connection
- V1 = bypass valve
- V2 = preloaded valve
- V3 = feeding valve

10. Installation, operating and maintenance instructions

10.1 Filter installation

When installing the filter, make sure that

- a) sufficient space is available to remove the filter element and the filter housing,
- b) the filter mounting hole in the tank top is not excessively large, to ensure proper sealing,
- c) the filter is free of tension after installation. Preferably the filter should be installed with the filter housing pointing downwards. In this position the optical dynamic pressure indicator is accessible and visible.

10.2 Connection of the electrical dynamic pressure indicator

The electrical dynamic pressure indicator is connected via a blade terminal 2x6.3x0.8. The electrical vacuum pressure switch is connected via a blade terminal 2x6.3x0.8.

10.3 When must the filter element be replaced?

1. Filters equipped with electrical dynamic pressure indicator: There may be an electrical signal during cold starts. If the electrical signal does not go out at operating temperature, the filter element has to be replaced after the end of the shift.
2. Filters without dynamic pressure indicator: The filter element should be replaced after the trial run or flushing of the system. Afterwards follow the manufacturer's instructions.
3. Always make sure you have original FGC spare elements in stock. Disposable elements (PS and Mic) cannot be cleaned.

10.4 Element replacement

1. Stop the system and relieve the filter from pressure.
2. Unscrew the filter housing by turning counter-clockwise.
3. Pull the filter housing with element upwards and out.
4. Remove the filter element by moving it gently backwards and forwards.
5. Clean the filter housing with a suitable medium.
6. Check the O-rings on the filter cover and the filter housing for damage. Replace these if necessary.
7. Make sure that the order number on the spare element corresponds to the order number on the filter name plate.
8. Remove the filter element from the plastic sleeve and reassemble the filter in reverse order (points 1-4).

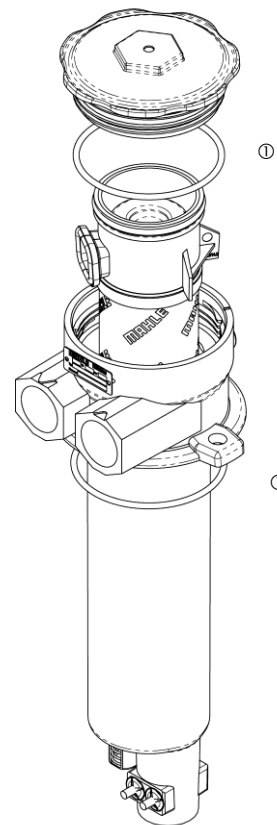

11. Spare parts list

Order numbers for spare parts		
Position	Designation	Order number
①	Pi 55010	
	Seal kit for housing	
	NBR	72355714
	Fluororubber	72355715
	EPDM	72355716

Filtration Group GmbH
Schleifbachweg 45
D-74613 Öhringen
Phone +49 7941 6466-0
Fax +49 7941 6466-429
fm.de.sales@filtrationgroup.com
www.filtrationgroup.com
72403143.03/2017

Suction return line filter Pi 550 up to NG 100